

- Measurement of single or repetitive flashes
- Calibrated for absolute spectral irradiance from 220 to 2150 nm
- Acquisition of the flash by a (multiple) array spectroradiometer system
- Flash measurement time 1.2 ms
- Simultaneous measurement spanning the complete spectral range

WE BRING QUALITY TO LIGHT

APPLICATION NOTE

Flash Lamp Measurement

Measurement Procedure

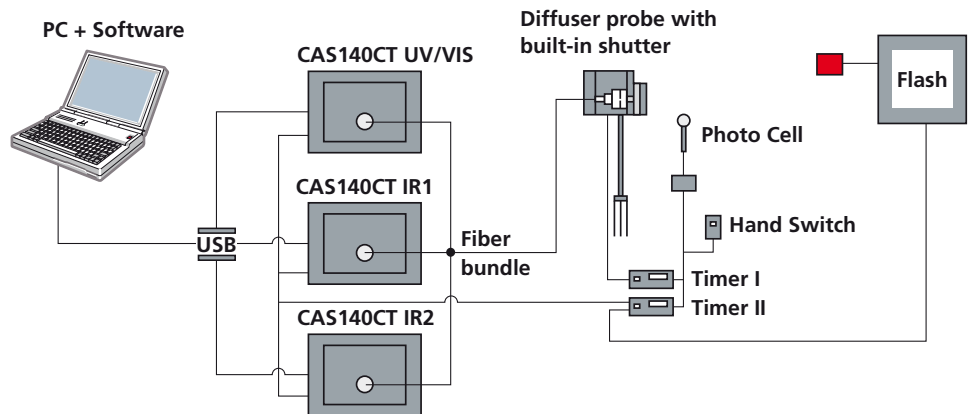

Multiple CAS140CT array spectroradiometers simultaneously measure the complete spectral irradiance of a flash. The diffuser probe is equipped with a fast mechanical shutter to define the measurement window.

Special software and hardware will prepare the triggering and collect the data. Data can be saved as a complete spectrum or separately for each spectrometer or sub-range. The spectra will be saved in (spread sheet compatible) ASCII format.

Two methods can be used for the measurement:

a) Measurement triggered by the flash using a photo cell: One timer device

will control the delay between the photo cell signal and start of the spectrometer measurement(s). A second timer will control the shutter (delay until opening and duration). Minimum measurement time is 4.5 ms.

b) Measurement initiated by a hand switch. Flash will be triggered by the system (timer box): One timer will control the delay between the start pulse from the spectrometer electronics and the flash trigger output. A second timer controls the shutter operation (opening and duration). The minimum measurement time is 1.2 ms.

The delays will be fixed (adjustable, but not via software!). The shutter is a separate, independent part of the set-up.

Spectroradiometer Specifications

The trigger signal from the photo cell or spectrometer electronics starts the simultaneous acquisition of the spectrum. The shutter defines the “effective” measurement time. It is typically shorter than the minimum integration time. Results will then be evaluated by the software.

Single CAS140CT-154 Array Spectroradiometer	
Spectral range	250-1050 nm or 300-1100 nm
Spectral resolution	3.7 nm
Wavelength accuracy	0.3 nm
Multiple CAS140CT Array Spectroradiometers	
Spectral range	220-2150 nm, divided into three sub-ranges UV-VIS, IR1, IR2
Spectral resolution	CAS140CT-152: 220-800 nm (100 micron slit): ≤ 2.7 nm CAS140CT-171: 780-1650 nm (250 micron slit): ≤ 21 nm CAS140CT-175: 1500-2150 nm (500 micron slit): ≤ 28 nm
Wavelength accuracy	CAS140CT-152: 220-800 nm $\leq \pm 0.3$ nm CAS140CT-171: 780-1650 nm $\leq \pm 0.5$ nm CAS140CT-175: 1500-2150 nm $\leq \pm 1.5$ nm
General	
Blocking of higher diffraction orders	By use of order sorting filters (built into the spectroradiometer)
Status	Spectrometer status LED and software error message
Minimum total irradiance	(for typical AM0 solar spectrum shape) UV-VIS-IR1: > 0.5 kW/m ² IR2: > 2.0 kW/m ²

Optical probe with high-speed shutter

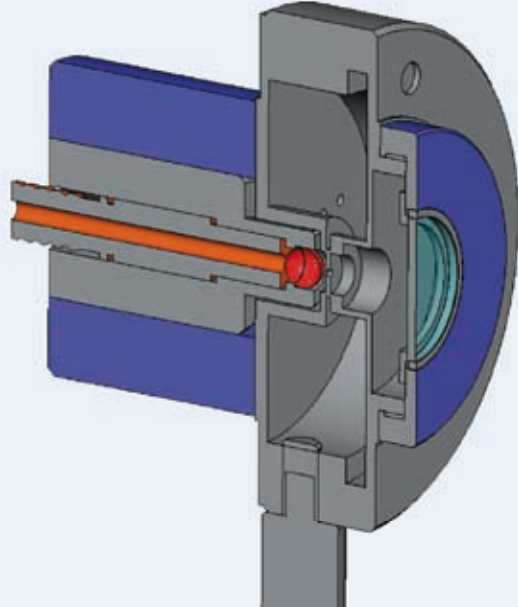
General	Optical input into the spectrograph through fiber coupled light diffusing probe.
Diffuser probe with built-in mechanical shutter	
Fiber guide:	A 3 m long fiber bundle will be used to connect the probe to the optical input of the CAS140CT. The bundle is split into multiple arms and has fiber bundle ferrules fitted for the IS fiber adapters (PLG).
Shutter:	<ol style="list-style-type: none"> 1. Use of a mechanical shutter to close the optical port during dark current calibration (built into the CAS140CT). 2. Additional customized fast mechanical shutter is positioned between the diffuser and the fiber input 3. Timing of the fast mechanical shutter: <ol style="list-style-type: none"> (a) Electronics response delay (reaction time) until opening is about 500 μs. (b) Opening time is 200 μs (fully closed until fully open). (c) Closing time is 300 μs (fully open until fully closed). (d) Minimum shutter open time (before next closing) is 700 μs.

Measurement timing

Intensity plateau	The flash pulse has constant irradiance values (intensity plateau) during a known time interval. The measurement is done within this window.
Timing of the flash pulse	There are two operation modes: a) System will be triggered by the flash (e.g. via a photo cell): Measurement can start ≥ 3 ms after flash start, measurement window ≥ 1.2 ms (stable plateau). b) System will trigger the flash: Measurement can start $\geq 600 \mu\text{s}$ after flash, measurement window ≥ 1.2 ms (stable plateau)

Graph displaying the photo cell triggered measurement Method (a)

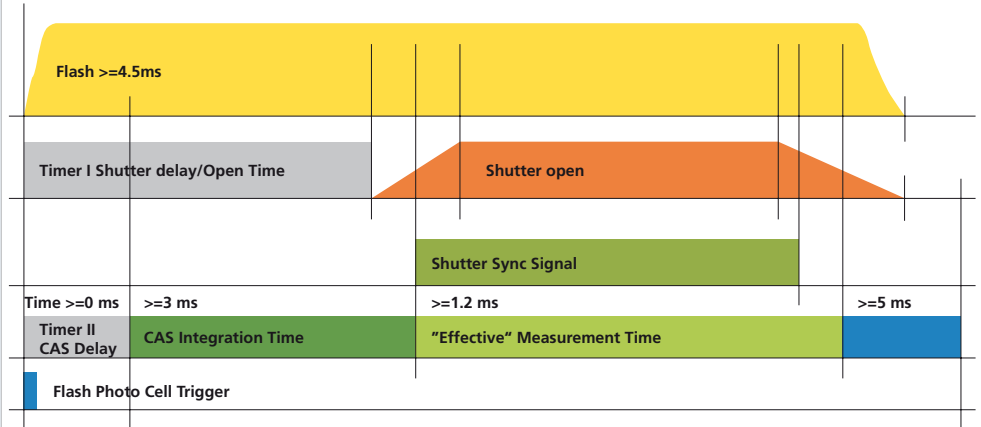

Graph displaying the measurement with system triggering of the flash (example) Method (b)

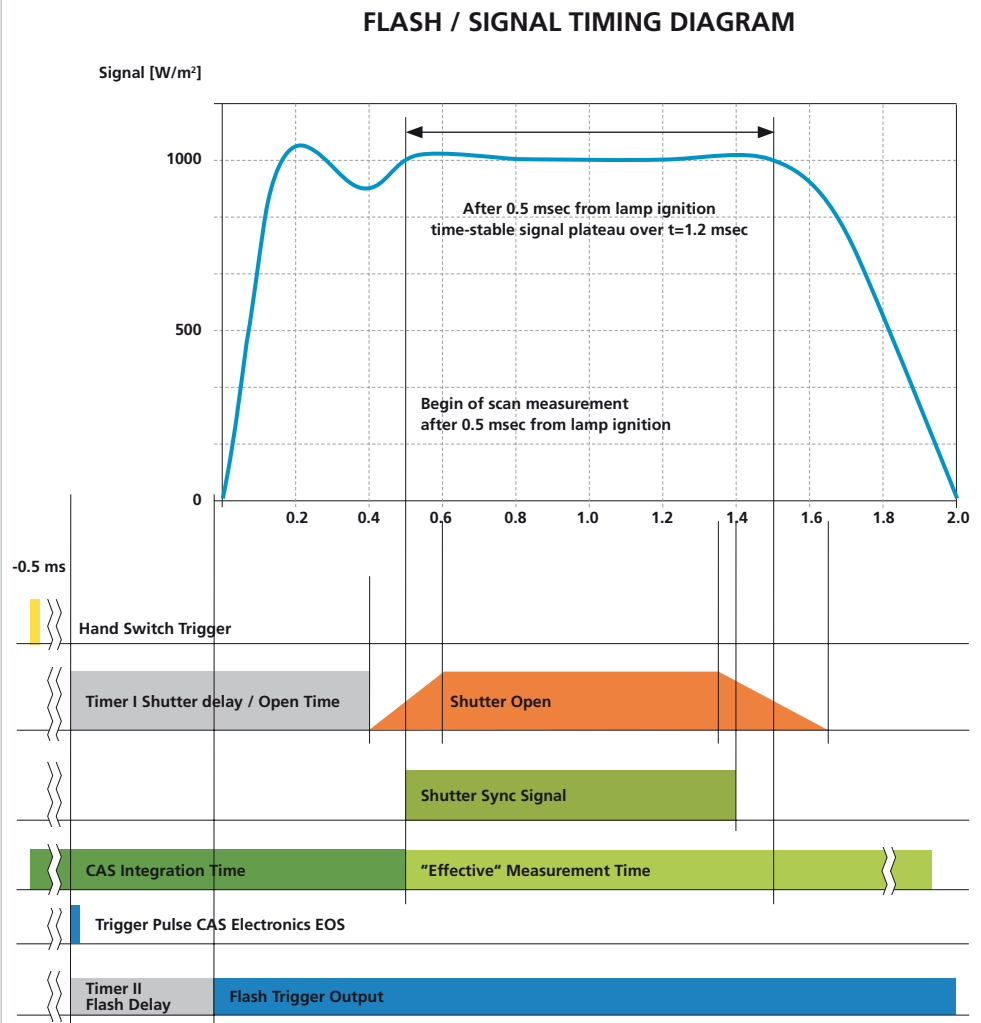

Ordering information

Flash Lamp Measurement System	
CAS-FLM-10	Basic setup including - optical probe with diffuser (optical fiber not included) - high-speed shutter - timer box and trigger switch - complete cables - system integration with CAS140CT
CAS-FLM-20	Photo detector for triggering the timer box
SW-310	Multi-CAS software for Windows 2000/XP - simultaneous measurement of multiple CAS140CT spectrometers via USB interface - control and synchronization of high-speed shutter - includes CAS DLL
Array Spectroradiometers with USB Interface	
CAS140CT-154	250 to 1050 nm or 300 to 1100 nm
CAS140CT-152	200 to 800 nm
CAS140CT-171	780 to 1650 nm
CAS140CT-175	1500 to 2150 nm
CAS140CT-332	250 µm slit for CAS140CT-171
CAS140CT-333	500 µm slit for CAS140CT-175
Optical Fiber Bundles	
OFG-424	Fiber bundle; 1.5 diam, 2 m length, 190 to 1350 nm
OFG-561	Bifurcated fiber bundle; 2 arms with 1.5 mm diam. each combined to one fiber bundle with 2.1 mm diam.; LUV fibers for UV-VIS arm and LIR fibers for IR arm; 3 m total length; 190 to 2500 nm
OFG-571	Trifurcated fiber bundle; 3 arms with 1.5 mm diam. each combined to one fiber bundle with 2.6 mm diam.; LUV fibers for UV-VIS arm and LIR fibers for two IR arms; 3 m total length; 190 to 2500 nm

Recommended Configurations

	One Spectrometer	Two Spectrometers	Three Spectrometers
Spectral Range	250 to 1050 nm or 300 to 1100 nm	220 to 1650 nm	220 to 2150 nm
CAS140CT models	CAS140CT-154	CAS140CT-152, CAS140CT-171, -332	CAS140CT-152, CAS140CT-171, -332 CAS140CT-175, -333
Optical fiber bundle	OFG-424	OFG-561	OFG-571
Fiber plug adapters	PLG-420	PLG-420, PLG-440	PLG-420, 2x PLG-440
Calibrations	CAL-101, CAL-191	CAL-100, CAL-101, CAL-191	2x CAL-100, CAL-101, CAL-191
FLM Hardware and software	CAS-FLM-10, SW-310	CAS-FLM-10, SW-310	CAS-FLM-10, SW-310
Options	CAS-FLM-20	CAS-FLM-20	CAS-FLM-20
Support and training	SRV-112 and SRV-201	SRV-112 and 2x SRV-201	SRV-112 and 2x SRV-201

INSTRUMENT SYSTEMS GmbH

Neumarkter Str. 83
D-81673 Munich, Germany
Tel.: +49 89 454943-26
Fax: +49 89 454943-11
e-mail: info@instrumentsystems.de

www.instrumentsystems.de

