

- *Passive cooling with heat sink and fan*
- *Models for all common high-power LEDs*
- *PT100 temperature sensor*
- *Maximum LED power rating of 5 W*



WE BRING QUALITY TO LIGHT

LED-81x

Test Sockets for High-Power LEDs

**High-power
also means
high-temperature**

High-power LEDs pose a real challenge to users implementing lighting applications. But these high-wattage LEDs do not only generate high light outputs. The associated power dissipation also leads to a massive temperature rise in the component. The LED must be protected by suitable thermal management in

order to prevent significant shortening of its service life or even its destruction. What's more, the temperature of the LED chip has an enormous influence on the light output emitted and on the radiation spectrum (LED color). The higher the temperature, the lower the light output.



 **Instrument
Systems**

KONICA MINOLTA Group

Reliable operation of LEDs with the LED-81x test sockets

Test sockets from the LED-81x series enable high-power LEDs with wattages of up to 5 W to be operated reliably and safely. These sockets have been designed such that the heat generated at the LED is quickly dissipated to the

ambient air. This effect is assisted by a fan. A PT100 sensor – whose measurements can be read out at a suitable measuring device – is integrated to monitor the temperature.

Design, Centering cap concept, Mechanical functionalities

The LED-81x test sockets with passive cooling are optimized for one particular type of high-power LED. The perfect fit of the test sample in the test socket and the centering cap with locking mechanism guarantee correct mounting of LEDs every time. Furthermore, this design also makes changing over LEDs quick and easy.

The range of test sockets covers all commonly available models from the world's leading LED manufacturers, as well as small Level 2 printed circuit boards (e.g. Luxeon Star). The LED-81x series is constantly being expanded to include new LED models. Customer-specific test sockets can also be supplied on request.

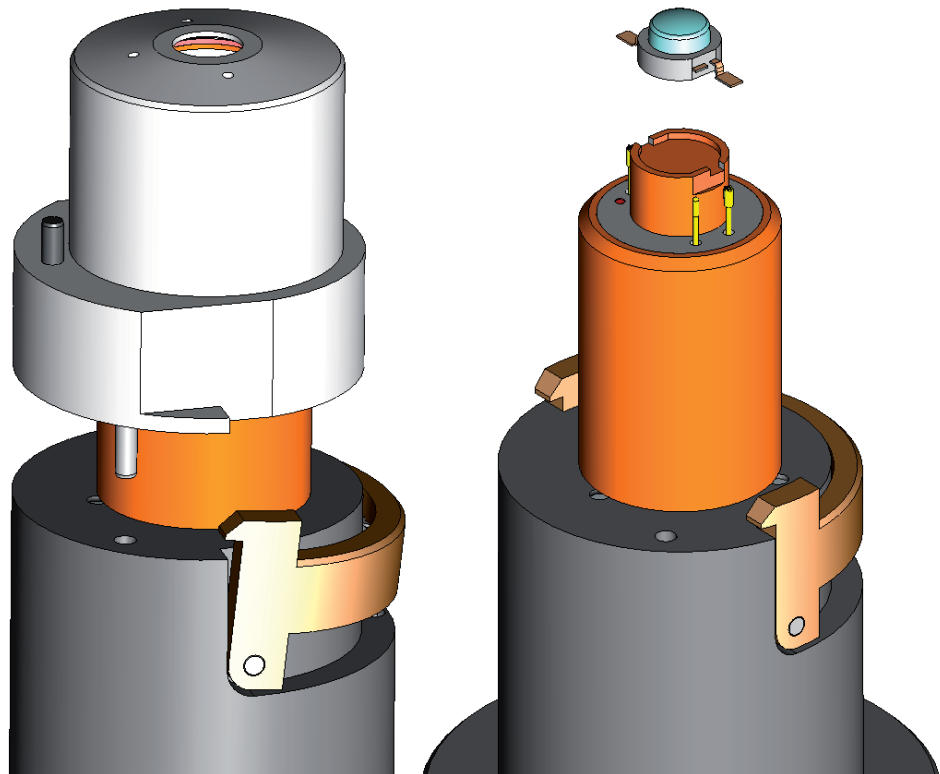

Two different centering caps are used depending on the optical quantity to be measured:

- A sand-blasted, white anodized centering cap is used to measure luminous flux with integrating spheres (this centering cap belongs to the scope of delivery of the test socket).
- A black anodized centering cap is used to measure the luminous intensity using CIE-compliant measurement adapters for the I_{LED-A} und I_{LED-B} measurement geometries (cap optional).



Efficient cooling of the LED

The heat load at the LED is dissipated by means of a gold-plated copper-zirconium rod which houses a PT100 temperature sensor. The sensor is positioned immediately below the contact surface for the test sample and in this way ensures maximum measuring accuracy. The high thermal conductivity of the copper-zirconium rod and the built-in fan ensure efficient cooling of the LED and protect the LED against being destroyed when ambient temperatures are high. The test sockets can be used under ambient temperatures ranging between 15 and 35°C.



Precise contacting using the 4-wire system

Electrical contacting of the LED is provided by a four-wire system. This enables not only the operating current to be applied but also the forward

voltage to be measured precisely at the same time. The LED-81x series test sockets are rated for maximum LED operating currents of 1.5 A.

Measuring the temperature

The measurements taken by the PT100 temperature sensor can be read out on any multimeter with an accurate resistance measurement function. Instrument Systems recommends the affordable precision temperature meter, LED-750. This unit has an RS-232 inter-

face for connection to a PC. A Keithley 2400/2600 series sourcemeter is highly suitable as the current source because it can also be used to measure the forward voltage of the LED with great accuracy.



Data and specifications

Thermal specifications	
Maximum temperature at PT 100	85°C
Electrical specifications	
Max. LED operating current	1.5 A
Max. power dissipation	5 W
Operating conditions	
Temperature range	15°C – 35°C
Max. humidity	70% rF
General specifications	
Length	150 mm
Weight	0.75 kg

Ordering information

Order No.	Description
Test sockets for high-power LEDs	
LED-811-1	For LUMILEDS LUXEON EMITTER LEDs (Type: Batwing, Lambertian, High Dome; Side Emitting); with max. 5 W power dissipation; passive cooling via heat sink and fan; incl. PT100 temperature sensor and 4-wire connection; socket dimensions: 7.95 x 7.3 mm; incl. centering cap with 25 mm diam. for luminous flux measurement.
LED-811-2	For LUMILEDS LUXEON K2 LEDs; with max. 5 W power dissipation; passive cooling via heat sink and fan; incl. PT100 temperature sensor and 4-wire connection; socket dimensions: 7.5 x 7.5 mm; incl. centering cap with 25 mm diam. for luminous flux measurement.
LED-811-5	For LUMILEDS LUXEON STAR LEDs; with max. 5 W power dissipation; passive cooling via heat sink and fan; incl. PT100 temperature sensor and 4-wire connection; incl. centering cap with 25 mm diam. for luminous flux measurement.
LED-812-1	For OSRAM OS GOLDEN DRAGON LEDs; with max. 5 W power dissipation; passive cooling via heat sink and fan; incl. PT100 temperature sensor and 4-wire connection; socket dimensions: 7.1 x 6.1 mm; incl. centering cap with 25 mm diam. for luminous flux measurement
LED-813-1	For CREE XLamp 7090 LEDs; with max. 5 W power dissipation; passive cooling via heat sink and fan; incl. PT100 temperature sensor and 4-wire connection; socket dimensions: 7.2 x 9.2 mm; incl. centering cap with 25 mm diam. for luminous flux measurement
LED-813-2	For CREE XLamp 4550 LEDs; with max. 5 W power dissipation; passive cooling via heat sink and fan; incl. PT100 temperature sensor and 4-wire connection; socket dimensions: 5.2 x 4.6 mm; incl. centering cap with 25 mm diam. for luminous flux measurement
LED-814-1	For NICHIA JUPITER NCCx022 LEDs; with max. 5 W power dissipation; passive cooling via heat sink and fan; incl. PT100 temperature sensor and 4-wire connection; socket dimensions: 7.4 x 8.9 mm; incl. centering cap with 25 mm diam. for luminous flux measurement
Accessory for LED-81x test socket	
LED-811-1-3	Centering cap with 25 mm diameter for luminous intensity measurement; for LUMILEDS LUXEON EMITTER test socket LED-811-1; incl. compensation rings
LED-811-2-3	Centering cap with 25 mm diameter for luminous intensity measurement; for LUMILEDS LUXEON K2 test socket LED-811-2
LED-811-5-3	Centering cap with 25 mm diameter for luminous intensity measurement; for LUMILEDS LUXEON STAR test socket LED-811-5
LED-812-1-3	Centering cap with 25 mm diameter for luminous intensity measurement; for OSRAM OS GOLDEN DRAGON test socket LED-812-1
LED-813-1-3	Centering cap with 25 mm diameter for luminous intensity measurement; for CREE XLamp 7090 test socket LED-813-1
LED-813-2-3	Centering cap with 25 mm diameter for luminous intensity measurement; for CREE XLamp 4550 test socket LED-813-2
LED-814-1-3	Centering cap with 25 mm diameter for luminous intensity measurement; for NICHIA JUPITER NCCx022 test socket LED-814-1

Instrument Systems GmbH

Kastenbauerstr. 2
D-81677 Munich, Germany
Tel.: +49 89 454943-0
Fax: +49 89 454943-11
info@instrumentsystems.de
www.instrumentsystems.de



KONICA MINOLTA Group